

BOLT : SUS304 M8\*50  
NUT : SUS304 M8 SPRING-WASHER/NYLON

LENS:HARDENED GLASS

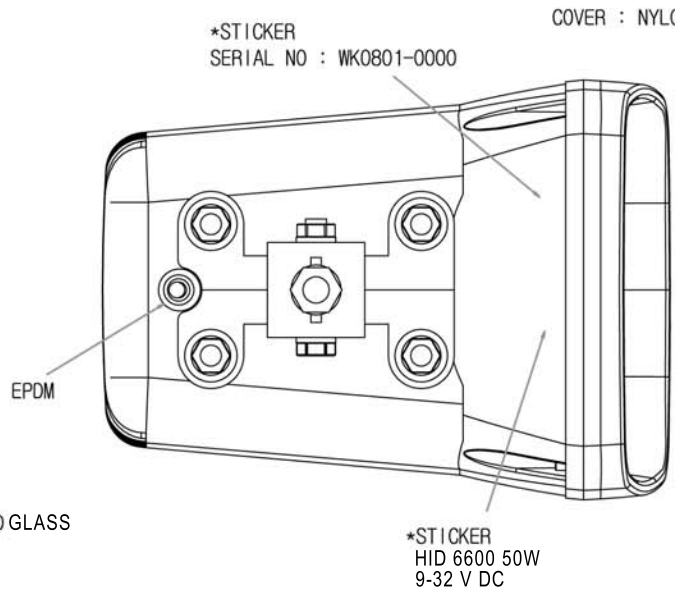

EPDM

\*STICKER  
SERIAL NO : WK0801-0000

COVER : NYLON GLASS13% BLACK

\*STICKER  
HID 6600 50W  
9-32 V DC

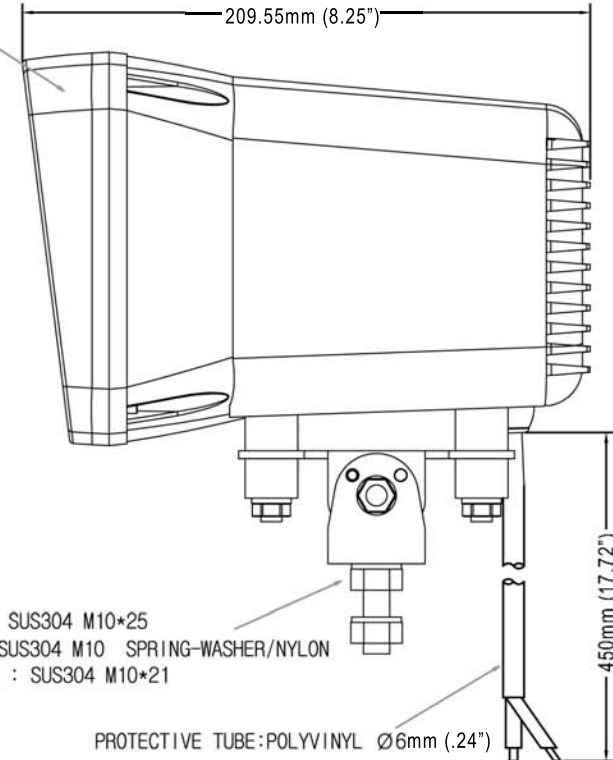

BOLT : SUS304 M10\*25  
NUT : SUS304 M10 SPRING-WASHER/NYLON  
WASHER : SUS304 M10\*21

PROTECTIVE TUBE:POLYVINYL Ø6mm (.24")

POWER LEAD WIRE : AVSS 2.0 (AWG #12)  
-POSITIVE:RED  
-GROUND:BLACK

BODY : NYLON GLASS13% BLACK

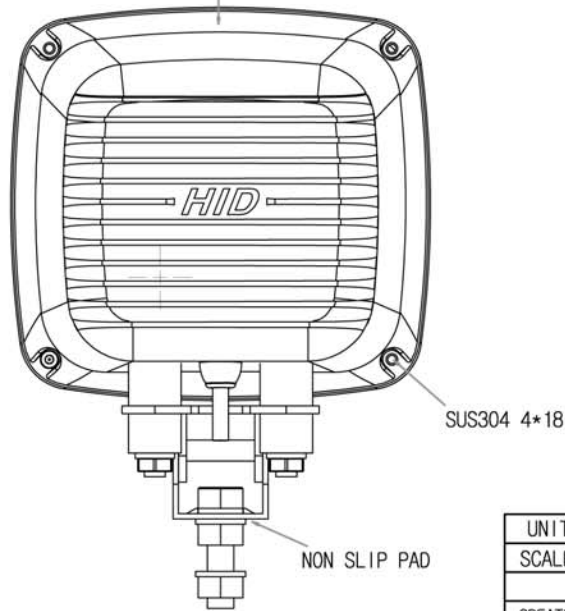

SUS304 4\*18

NON SLIP PAD

SPECIFICATION

1. OPERATING VOLTAGE : 9-32 VOLT DC
2. BALLAST : 50 WATT HID
3. LAMP : 50 W / 5000K ±500
4. REFLECTOR : PRESS / VACUUM METALIZED
5. LENS : HARDENED GLASS
6. WEIGHT: 2Kg (4.4lbs)
7. VIBRATION : 8.6Gms
8. WEATHER PROOF & DUST RESISTANT
9. TEMPERATURE : -40°C~85°C
10. LIFE : 2,000hrs
11. IP Rating : IP65

**Vision**  
Global Lighting Systems  
visionxusa.com

UNIT	mm	DRAWING	CHECK	APPROVAL	TITLE	6600
SCALE						
CREATED	2008.07.04					
[VX] Vision X					DRAWING NAME	VX-TS-6600