



# SOLSTICE PRIME 7 LED

The Solstice Prime Series from Vision X combines traditional form factor and single-bolt mounting with the energy-efficient benefits of LED for the ultimate OE upgrade option for commercial and industrial vehicles that use HID and Halogen fixtures. The Solstice Prime Series features Prime Drive ETM (Electronic Thermal Management) that controls the LED temperature to ensure a prolonged LED lifespan. Additionally, the unique vertical channeled heat sink increases heat dissipation and further prolongs the lifespan.

## Features and Benefits:

- Integrated Electronic Thermal Management (ETM)
- Next Gen LED Driven to 90% Efficiency
- Vertical Fins Maximizing Heat Dissipation
- PWM Integrated Dimming Circuitry
- 90% Optically Pure



## SPECIFICATIONS

### MECHANICAL:

Fixture Weight:	4.52 lb / 2.05 kg
Dimensions:	7.17" x 6.89" x 3.17" 182.1mm x 175mm x 80.5mm
Mounting:	105° Adjustable Trunnion Bracket Mount

### TECHNICAL:

Type of LEDs:	10W CREE LED
Raw Lumens:	6,020 lm
Effective Lumens:	4,214 lm
Beam Pattern:	20° 40°
Wattage:	70W
Amp Draw:	4.17A @ 16.8V DC
Color Temperature:	5000K
Operating Voltage:	9-48V DC
Operating Temp:	-40°C ~ 80°C
Lifespan:	50,000 hrs
EMC:	CISPR 25 Class 3
Polarity:	Reverse Polarity Protection
Connector:	Integrated Deutsch Connector with Plug-and-Play Harness
Housing Material:	Die-Cast Aluminum
Lens:	Polycarbonate
Finish:	Gloss Black (Available in White)

### RATINGS:

Ingress Protection:	IP-68 IP69K
Vibration Rating:	15.6 Grms
Warranty	3 Years

ITEM #:	PART#	BEAM PATTERN
XIL-SP720	4009868	20° Narrow
XIL-SP740	4009875	40° Wide

## 2D DRAWING:

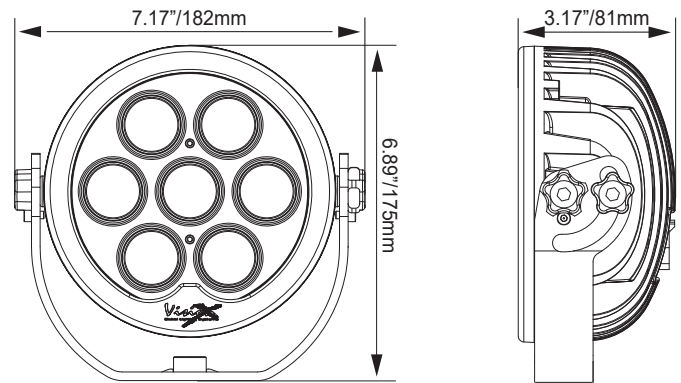

## BEAM PATTERNS:

### XIL-SP720 | 20°

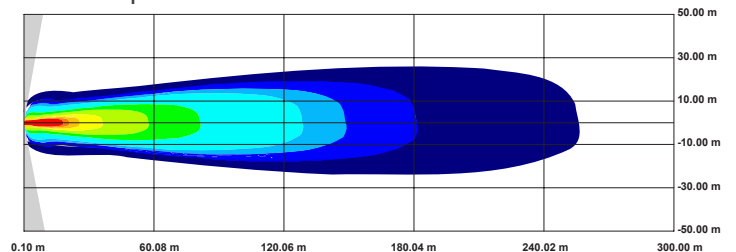

### XIL-SP740 | 40°

