



OVAL VL SERIES LED LIGHTS

LIGHT DUTY COMMERCIAL

The VL-Series LED Light Duty offers outstanding light output in a functional design which can be easily adjusted with the single bolt bracket. High quality construction and components enable VL-Series LED Light Duty to withstand vibration up to 15.6 Grms. Built-in reverse polarity protection helps prevent accidental damage caused by incorrect installation. VL-Series LED Light Duty work lighting is a high value, versatile range designed for many light duty commercial applications.

Features and Benefits:

- Ultra Bright Cree LEDs
- 3 Housing Options
- 2 Output Options
- Universal Single Bolt Mounting



TECHNICAL	6 LED	8 LED
Fixture Weight:	0.97 lbs (0.44 kg)	1.50 lbs (0.68 kg)
Fixture Dimensions:	5.59" x 4.39" x 2.21"	5.59" x 4.39" x 2.21"
Mounting:	Universal Single Bolt	Universal Single Bolt
LED:	XTE (CREE)	XTE (CREE)
Raw Lumens:	3,168 lm	4,224 lm
Effective Lumens:	2,218 lm	2,957 lm
Wattage:	30W	40W
Beam Pattern:	40°	40°
Amp Draw:	2.5A@12V	3.33A@12V
Color Temperature:	5700 Kelvin	5700 Kelvin
Operating Voltage:	10-32V DC	10-32V DC
Operating Temperature:	-40°C ~ 85°C	-40°C ~ 85°C
Lifespan:	50,000 hrs	50,000 hrs
Reverse Polarity Protection:	✔	✔
Connector:	2 Pin Deutsch	2 Pin Deutsch

CONSTRUCTION	6 LED	8 LED
Housing:	Die-Cast 6061 Aluminum	Die-Cast 6061 Aluminum
Finish:	Gloss Black	Gloss Black
Lens:	Polycarbonate	Polycarbonate
Bracket Material:	Powder Coated Steel	Powder Coated Steel

RATINGS	6 LED	8 LED
EMC Emission:	(CISPR 25) Class 3	(CISPR 25) Class 3
Ingress Protection:	IP-67, IP69k	IP-67, IP69k
Vibration Rating:	15.6 Grms	15.6 Grms
Warranty:	1 Year	1 Year

PART #:	LED COUNT	DEUTSCH CONNECTOR
VW0050640	6	Included
VLO050640	6	Not Included
VW0050840	8	Included
VLO050840	8	Not Included

2D DRAWING

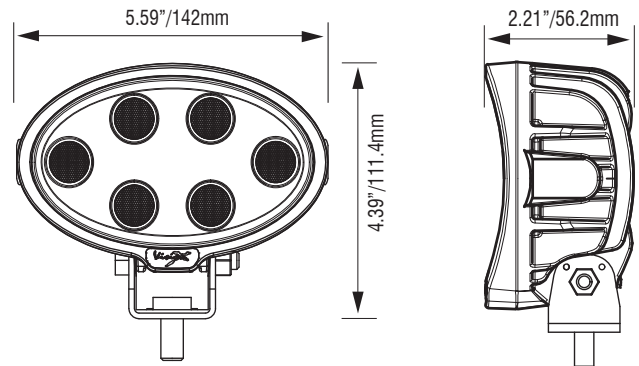

BEAM PATTERN

