



140W AC LED FIXTURE

CORROSION RESISTANT SERIES

DESCRIPTION

The 140-Watt AC LED light fixture features a stainless steel trunnion bracket and stainless steel fasteners to fight against chemically harmful environments. Included with the light is a quick connect cable allowing for simple installation and speedy maintenance. The 140W is IP-68/IP69K rated and UL1598a rated for wet locations.

- Protective Coating Eliminates Corrosion in High-Risk Environments

SPECIFICATIONS

MECHANICAL:

Fixture Weight:	24 lbs (10.9kg)
Shipping Weight:	26.9 lbs (12.2kg)
Mounting/ Entries:	(1) 3/4" NPT - TOP (2) 3/4" NPT 90° - SIDES (2) 3/4" NPT 45° - SIDES

TECHNICAL:

Operating Voltage:	90 - 305VAC 127 - 431VDC 180-528VAC <i>High Voltage Available</i>
Lumens:	21,000 lm
Wattage:	140W
Operating Temp:	-40°C ~ 60°C
THD:	<20% (@load≥50% / 115VAC,230VAC) (@load≥75% / 277VAC)
Power Factor:	≥ 0.98/115VAC ≥ 0.95/230VAC ≥ 0.92/277VAC
Short Circuit:	Constant Current Limiting, Recovers Automatically After Fault Condition is Removed
Frequency:	47-63Hz

CONSTRUCTION:

Housing:	Plastic Tri-Coated Aluminum
Finish:	Gloss Yellow
Lens:	Polycarbonate

LED Light Engine / Driver

LED:	XP-L(CREE)
Amp Draw:	1.22A @ 115VAC 0.61A @ 230VAC 0.51A @ 277VAC
Lifespan:	50,000 hrs



PART #:	BEAM PATTERN
LSY063060STRQC	60°
LSY063090STRQC	90°

2D DRAWING:

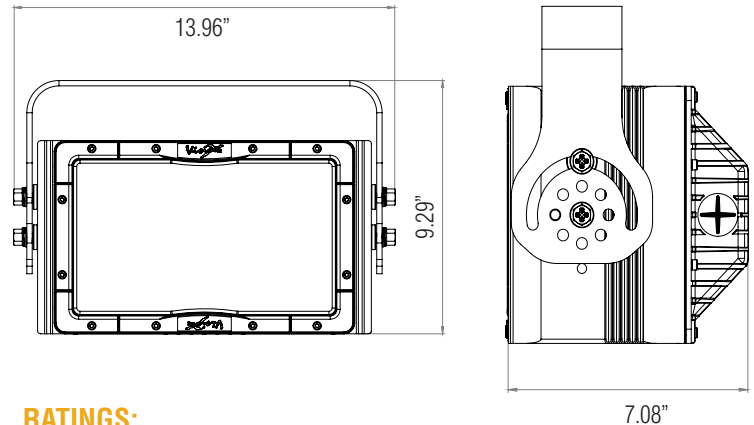

RATINGS:

EMC Emission:	Compliance to EN55015, EN55022 (CISPR22) Class B, EN61000-3-2 Class C (@Load ≥ 50%); EN61000-3-3
EMC Immunity:	Compliance to EN61000-4-2,3,4,5,6,8,11, EN61547, EN55024, Light Industry Level (surge immunity Line-Earth 4KV, Line-Line 2KV)
Ingress Protection:	IP-68, IP69k
UL 1598a Marine:	✓
Vibration Rating:	15.6 Grms
Warranty:	5 Years