



# 280W AC LED FIXTURE

## CORROSION RESISTANT SERIES

### DESCRIPTION

Designed to outshine and outlast the competition, the 280-Watt AC LED light fixture features a stainless steel trunnion bracket and stainless steel fasteners to fight against chemically harmful environments. Included with the light is a quick connect cable allowing for simple installation and speedy maintenance. The 280W is IP-68/IP69K rated and UL1598a rated for wet locations.

- Protective Coating Eliminates Corrosion in High-Risk Environments

### SPECIFICATIONS

#### MECHANICAL:

<b>Fixture Weight:</b>	37.05 lbs (16.81kg)
<b>Shipping Weight:</b>	40.05 lbs (18.17kg)
<b>Mounting/ Entries: (See Accessories)</b>	(1) 3/4" NPT - TOP (2) 3/4" NPT 90° - SIDES (2) 3/4" NPT 45° - SIDES

#### TECHNICAL:

<b>Operating Voltage:</b>	90 - 305VAC 127 - 431VDC 180-528VAC <i>High Voltage Available</i>
<b>Lumens:</b>	36,000 lm
<b>Wattage:</b>	280W
<b>Operating Temp:</b>	-40°C ~ 60°C
<b>THD:</b>	<20% (@load≥50% / 115VAC,230VAC) (@load≥75% / 277VAC)
<b>Power Factor:</b>	≥ 0.98/115VAC ≥ 0.95/230VAC ≥ 0.92/277VAC
<b>Short Circuit:</b>	Constant Current Limiting, Recovers Automatically After Fault Condition is Removed
<b>Frequency:</b>	47-63Hz

#### CONSTRUCTION:

<b>Housing:</b>	Plastic Tri-Coated Aluminum
<b>Finish:</b>	Gloss Yellow
<b>Lens:</b>	Polycarbonate Lens

#### LED Light Engine / Driver

<b>LED:</b>	XP-LHD(CREE)
<b>Amp Draw:</b>	2.43A @ 115VAC 1.22A @ 230VAC 1.01A @ 277VAC
<b>Lifespan:</b>	50,000 hr

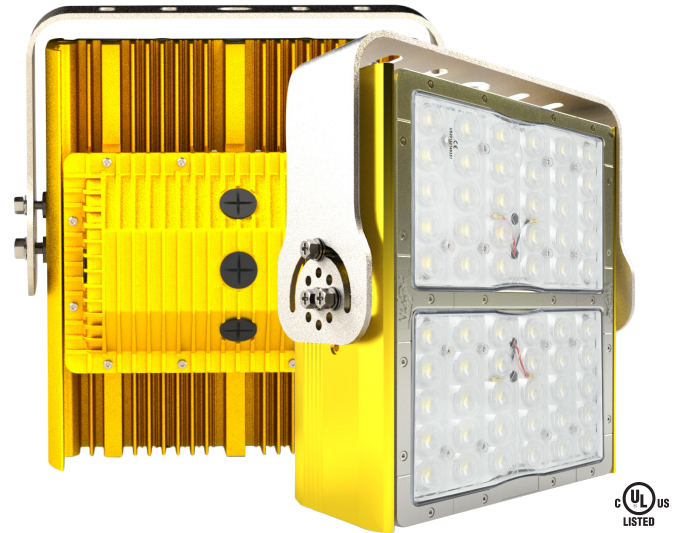

PART #:	BEAM PATTERN
LSY066060STRQC	60°
LSY066090STRQC	90°

#### 2D DRAWING:

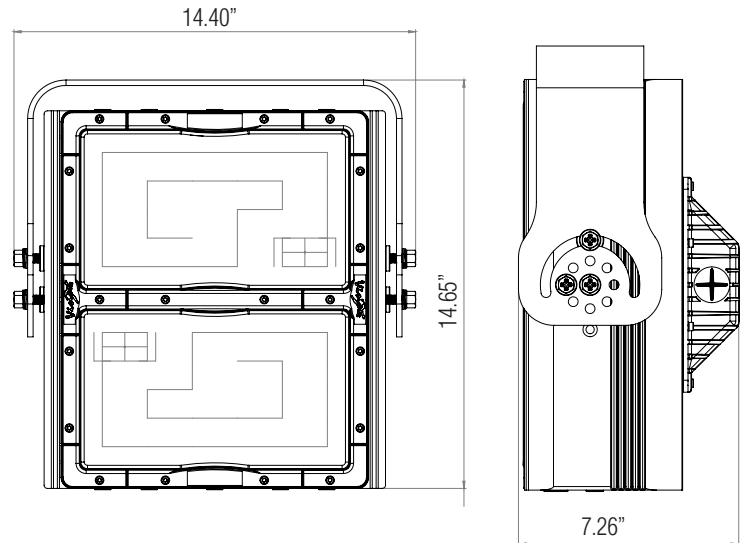

#### RATINGS:

<b>EMC Emission:</b>	Compliance to EN55015, EN55022 (CISPR22) Class B, EN61000-3-2 Class C (@Load ≥ 50%); EN61000-3-3
<b>EMC Immunity:</b>	Compliance to EN61000-4-2,3,4,5,6,8,11, EN61547, EN55024, Light Industry Level (surge immunity Line-Earth 4KV, Line-Line 2KV)
<b>Ingress Protection:</b>	IP-68, IP69k
<b>UL1598a Marine:</b>	✓
<b>Vibration Rating:</b>	15.6 Grms
<b>Warranty:</b>	5 Years