



280-WATT LED FIXTURE

Application

Designed to outshine and outlast the competition, the AC Spreader Lighting fixture features advanced electronic technology like Pulse Width Modulation, Electronic Thermal Management, and a Redundant Circuit Design.

SPECIFICATIONS 280-WATT STAINLESS STEEL

Mechanical Information:

Fixture Weight:	37.05 lbs (16.81kg)
Shipping Weight:	40.05 lbs (18.17kg)
Mounting/ Entries: (See Accessories)	(1) 3/4" NPT - TOP (2) 3/4" NPT 90° - SIDES (2) 3/4" NPT 45° - SIDES

Electric Specifications:

Operating Voltage:	90 - 305V AC 127 - 431V DC
Lumens:	36000 lm
Wattage:	280W
Operating Temp:	-40°C ~ 60°C
THD:	<20% (@load≥50% / 115VAC,230VAC) (@load≥75% / 277VAC)
Power Factor:	≥ 0.98/115VAC ≥ 0.95/230VAC ≥ 0.92/277VAC
Short Circuit:	Constant Current Limiting, Recovers Automatically After Fault Condition is Removed
Frequency:	47-63Hz
Vibration:	15.6Grms

Construction:

Housing:	Die-Cast 6061 Aluminum
Finish:	Gloss Grey
Lens:	Polycarbonate Lens

LED Light Engine / Driver

LED:	XP-LHD(CREE)
Amp Draw:	2.43A @ 115VAC 1.22A @ 230VAC 1.01A @ 277VAC
Lifespan:	50,000 hr



* High Voltage Available



PART #:

BEAM PATTERN

LSG066010STRHDQC (Stainless Steel Bracket)	10°
LSG066025STRHDQC (Stainless Steel Bracket)	25°
LSG066040STRHDQC (Stainless Steel Bracket)	40°
LSG066060STRHDQC (Stainless Steel Bracket)	60°
LSG066090STRHDQC (Stainless Steel Bracket)	90°
LAYUPC2M (Quick Connect)	-

2D DRAWING:

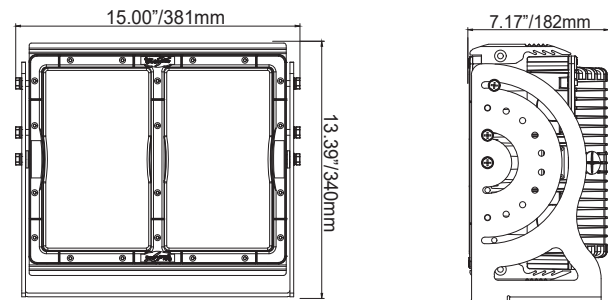

RATINGS:

EMC Emission:	Compliance to EN55015, EN55022 (CISPR22) Class B, EN61000-3-2 Class C (@Load ≥ 50%); EN61000-3-3
EMC Immunity:	Compliance to EN61000-4-2,3,4,5,6,8,11, EN61547, EN55024, Light Industry Level (surge immunity Line-Earth 4KV, Line-Line 2KV)
UL 1598A Marine:	✓
Ingress Protection:	IP-68, IP69k
Warranty:	5 years