



# SCENE | WORK LIGHTING

## WSL SURFACE MOUNT 20,500 LUMENS

Powered by 21 ultra-bright LED's, the sleek surface mounted light is provided in 10,000 lumen and 22,500 lumen models. Both WSL Surface Mount scene light models include two rows of wide patterned LED's for close in illumination and two rows of optically focused LED's for midrange and distance illumination. All LED's have internal downward aiming to provide daylight type ground and area illumination in a compact, flat surface mount housing. Mounting requires just a single 1" hole for wiring and four mounting screws. The WSL Surface Mount LED scene light fixture guarantees longer service light and 2-3 times the light output of halogen and HID pole light alternatives.

### Features and Benefits:

- 3 optical segments providing close area, wide-medium, and long-range lighting in a single fixture.
- Compact, flat surface mounting with a chrome ABS trim bezel.
- Polycarbonate lens is not attached by mounting screws preventing cracks from mounting or vibration.
- 10,000 lumen output model providing 6,500 effective lumens.
- Certifications: CE, RoHS, IEC 62471



### MECHANICAL

Fixture Weight:	7.28 lbs (3.3kg)
Mounting:	Surface Mount

### TECHNICAL

Raw Lumens:	20,500 lm
Effective Lumens:	12,290 lm
Wattage:	125W
Amp Draw:	10.41A @ 12V
Color Temperature:	5900 Kelvin
Operating Voltage:	9-32V DC
Operating Temperature:	-40°C - 85°C
Lifespan:	50,000 hrs
Polarity:	Reverse Polarity Protection

### CONSTRUCTION

Housing:	Die-Cast 6061 Aluminum
Finish:	ABS Chrome Bezel
Lens:	Polycarbonate

### RATINGS

EMC Emission:	(CISPR 25) Edition 3.0 (2008-03) Class 3
Ingress Protection:	IP-68, IP69k
Vibration Rating:	8.6 Grms
Warranty:	3 Years

### PART #:

WSL-125M

### WATTAGE:

125W

### 2D DRAWING

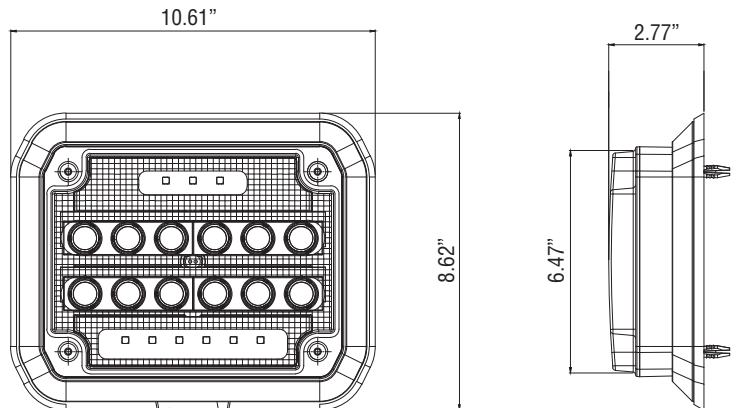

### BEAM PATTERN:

