



EYE WASH STATION LIGHTING

Industrial Emergency Eye Wash Applications



LED | LIGHTING CATALOG





50W JUNCTION BOX

Product Information

Project Name:
Date:
Type:

An all in one LED light and junction box, this industrial luminaire is designed to outshine and outlast the competition featuring advanced electronic technology like pulse width modulation, electronic thermal management and a Failsafe redundant circuit design. The bright green light emitted by the LEDs promises temporarily visually impaired workers to quickly and safely find their way to an eye wash station.

A built-in backup battery is also available. This version senses a power failure and immediately begins driving the LED load in emergency mode at reduced lumen output for a minimum 90 minutes, in accordance with emergency lighting codes (e.g., NFPA® Life Safety Code®).



MECHANICAL:

Fixture Weight:	8 lbs (3.8kg)
Shipping Weight:	10 lbs (4.5kg)
Mounting/ Entries: (See Accessories)	(6) 3/4" NPT - SIDES

TECHNICAL:

LED:	(Non-Optic) MHB-B(CREE) (Optics) XT-E2(CREE)
Lumens:	6000-7000 lm
Wattage:	50W
Amp Draw:	0.43A @ 115VAC 0.22A @ 230VAC 0.18A @ 277VAC
Operating Voltage:	90 - 305VAC 127 - 431VDC
Operating Temp:	-40°C - 60°C
Lifespan:	50,000 hrs
Frequency:	47-63Hz
THD:	<20% (@load≥50% / 115VAC,230VAC) (@load≥75% / 277VAC)
Power Factor:	≥ 0.98/115VAC ≥ 0.95/230VAC ≥ 0.92/277VAC
Short Circuit:	Constant Current Limiting, Recovers Automatically After Fault Condition is Removed
Polarity:	Reverse Polarity Protection
Battery Back-Up:	Version Available

CONSTRUCTION:

Housing:	Die-Cast 6061 Aluminum
Finish:	Gloss Grey
Lens:	Polycarbonate

PART #:	BEAM PATTERN	LED COLOR
LSG0330xxG	10°, 25°, 40° 60°, 90°	Green
LGB0330xxG (Battery Backup)		

2D DRAWING:

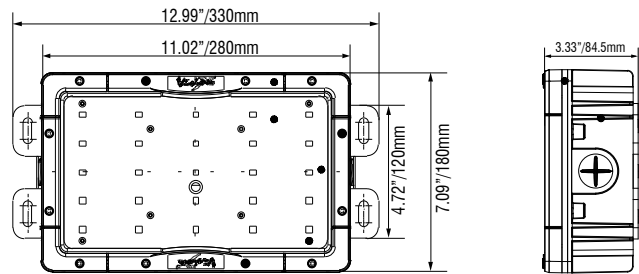

RATINGS:

EMC Emission:	Compliance to EN55022, EN61000-3-2 Class A, EN61000-3-3
EMC Immunity:	Compliance to EN55024, EN61000-4-2,3,4,5,6,8,11; light industry level(surge 2KV), criteria A
UL1598A Marine:	✓
Ingress Protection:	IP-68, IP69k
Vibration:	15.6 Grams
Warranty:	5 Years





10W JUNCTION BOX

Product Information

Project Name:
Date:
Type:

The all in one 10W junction box luminaire is small but powerful. This LED fixture also features pulse width modulation, electronic thermal management and a Failsafe redundant circuit design that allows the light to function even if half the light should fail in extreme conditions.

The 180° ultra-wide flood beam pattern and intense green color leads temporarily visually impaired workers quickly to an eye wash station aiming to prevent permanent eye damage.



MECHANICAL:

Fixture Weight:	2 lbs (0.9kg)
Shipping Weight:	4 lbs (1.8kg)
Mounting:	(4) 3/4" NPT - SIDES

TECHNICAL:

LED:	5630 (LG) X 40EA
Lumens:	1,000 lm
Beam Pattern:	180°
Wattage:	10W
Amp Draw:	0.09A@115V AC 0.04A @ 230V AC 0.04 @ 277V AC
Color Temperature:	-
Operating Voltage:	90-264V AC 127-370V DC
Operating Temp:	-40°C ~ 60°C
Lifespan:	50,000 hrs
Frequency:	47-63Hz
THD:	<20% (@load≥50% 115VAC,230VAC) (@load≥75% / 277VAC)
Power Factor:	≥ 0.98/115VAC ≥ 0.95/230VAC ≥ 0.92/277VAC
Short Circuit:	Constant Current Limiting, Recovers Automatically After Fault Condition is Removed
Polarity:	Reverse Polarity Protection
Battery Back-Up:	N/A

CONSTRUCTION:

Housing Material:	Die-Cast 6061 Aluminum
Finish:	Gloss Grey
Lens:	Polycarbonate

PART #:	BEAM PATTERN	COLOR
LSGSM40180PCVG	180° Ultra-Wide Flood	Green

2D DRAWING:

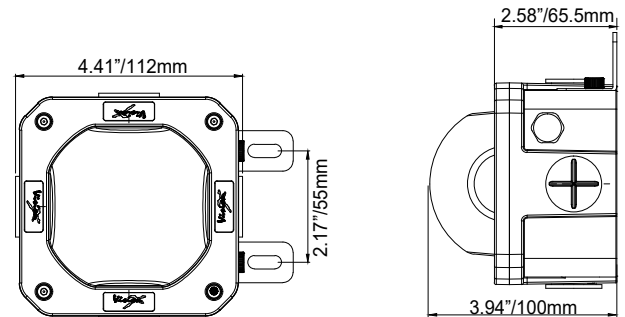

RATINGS:

EMC Emission:	Compliance to EN55022,EN61000-3-2 Class A ,EN61000-3-3
EMC Immunity:	Compliance to EN55024, EN61000-4-2,3,4,5,6,8,11; light industry level(surge 2KV), criteria A
UL1598A Marine:	<input checked="" type="checkbox"/>
Ingress Protection:	IP-68, IP69k
Vibration Rating:	15.6 Grms
Warranty:	5 Years





VISION X USA
1601 Boundary Blvd
Auburn WA 98001
United States of America
P: 253-218-2900
www.vxstructural.com



VISION X ASIA
23-7 Dongtansandan
9-gil Dongtan-myeon Hwaseong-si
Gyeonggi-do 18487, Korea
P: 82-32-515-4814
www.visionxlighting.com